

Figure 23 and Figure 24 show the basic structures of a standard and a 5 V tolerant I/O port bit, respectively. Table 38 gives the possible port bit configurations.

Figure 23. Basic structure of an I/O port bit

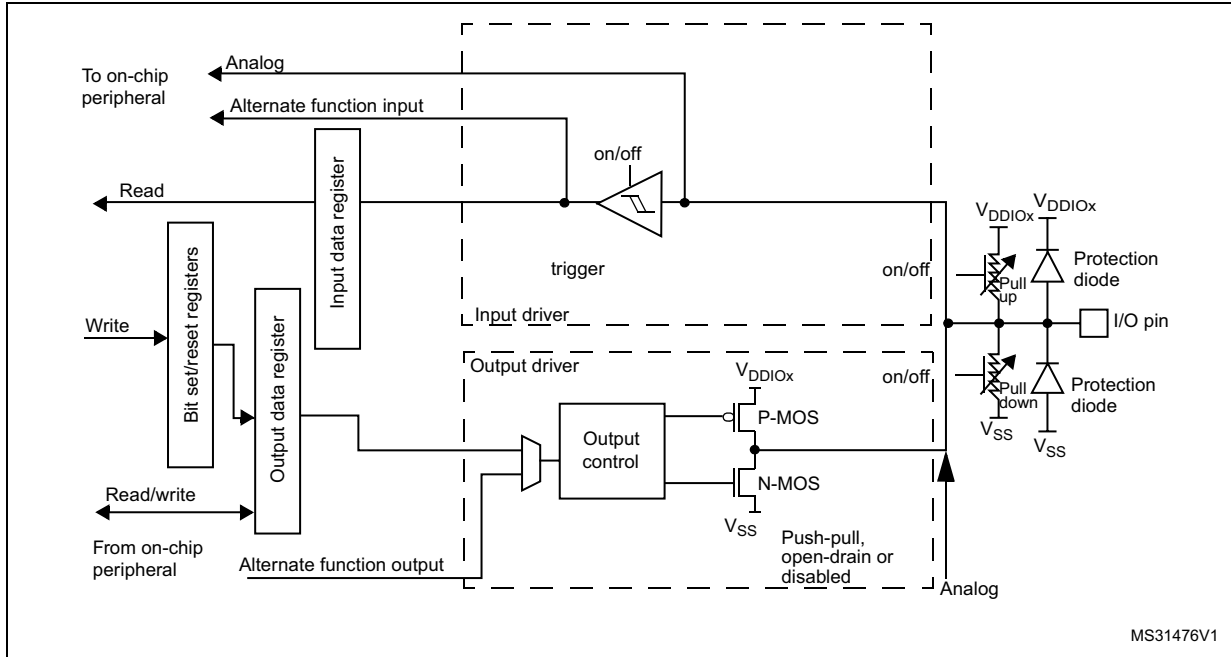
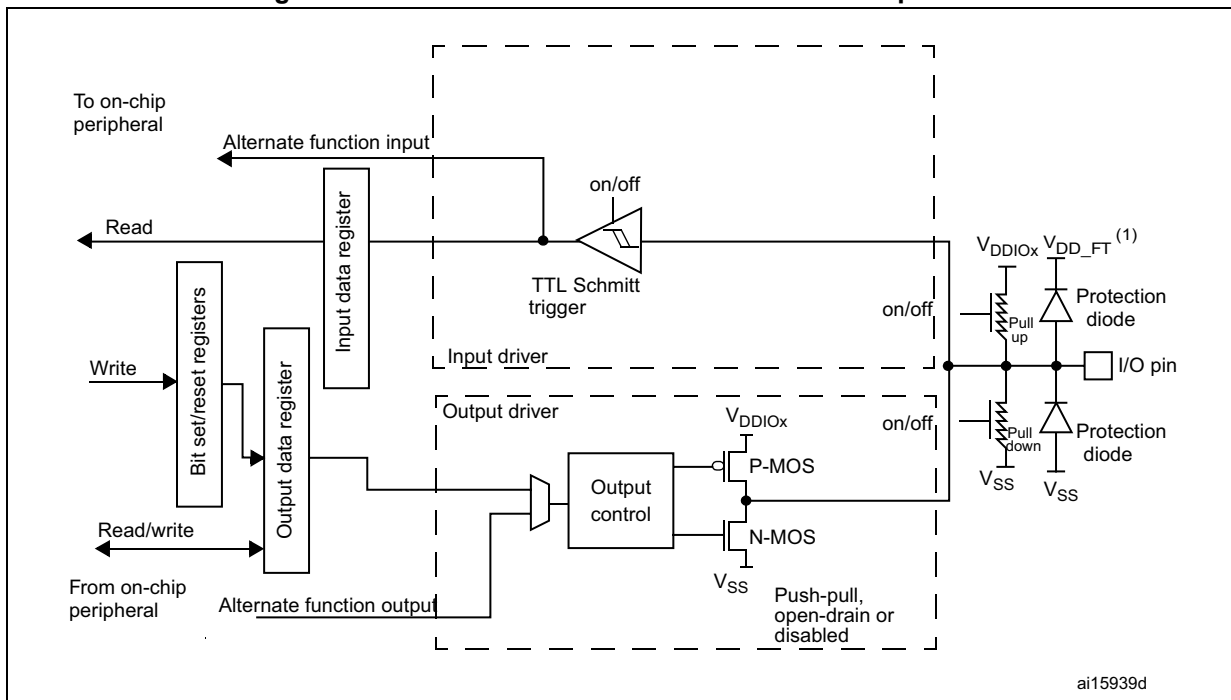

Figure 24. Basic structure of a five-volt tolerant I/O port bit



1. V_{DD_FT} is a potential specific to five-volt tolerant I/Os and different from V_{DD} .